

Top Drive Backup Wrench Deflector Plate Safety Wiring

Discussion

The backup wrench (BUW) manifold deflector plate (P/N DT15393) on 6027 top drives is designed to deflect pipe away from the hydraulic manifold mounted on the back of the gripper (see Figure 1 below and Figure 2 on page 2).

This bulletin details the recommended procedure to safety-wire the deflector plate to the top drive BUW as a secondary restraint.

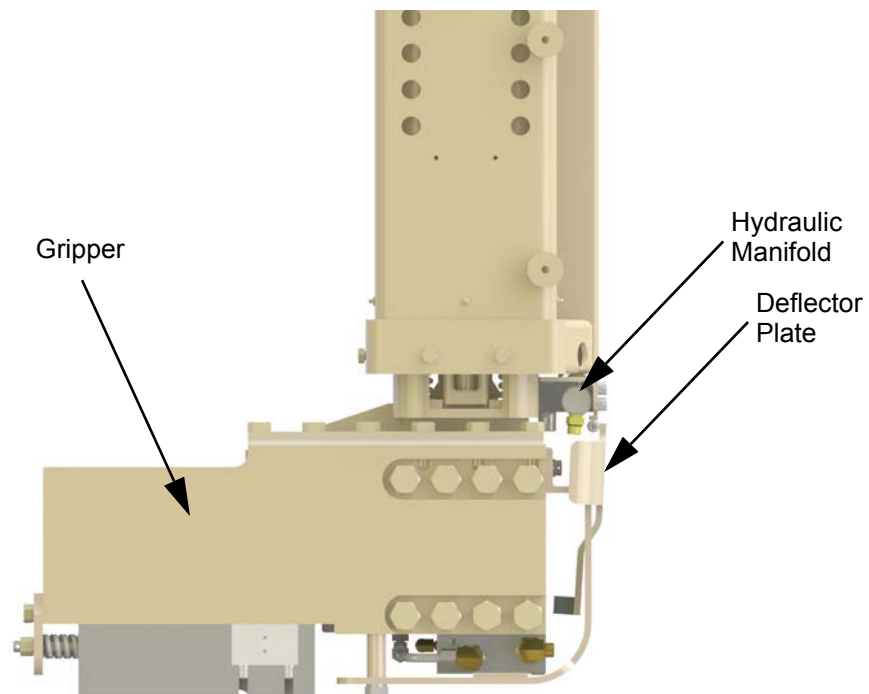

Figure 1: BUW gripper (side view).

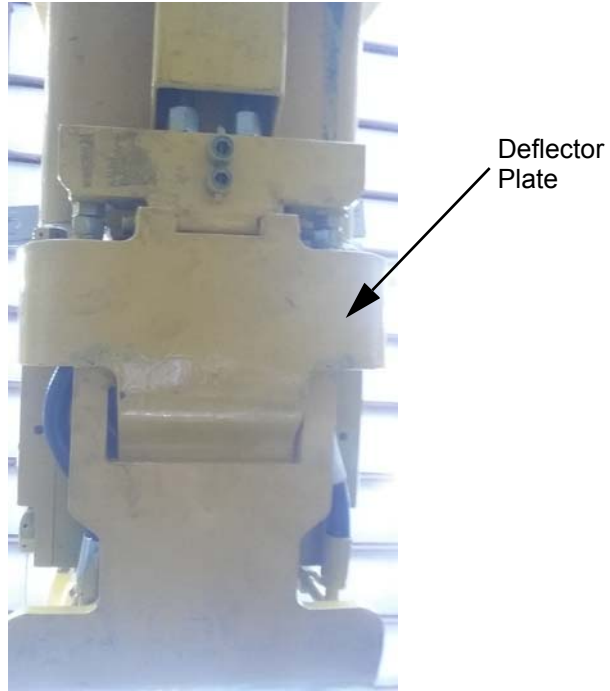

Figure 2: BUW gripper (back side).

Installing the Safety Wire

Necessary Equipment

- Multi-groove compression tool, $\frac{1}{16}$ "– $\frac{3}{16}$ " (P/N M10193)
- Wire rope, $\frac{3}{16}$ ", 7x19, stainless steel (P/N M21-2001-010), 33 in. length
- Oval ferrule, $\frac{3}{16}$ ", aluminum (P/N M19-3007-010)

Procedure

1. Cut a 33 in. length of wire rope.
2. Pass the length of wire rope through the tube welded to the inside surface of the valve guard (see Figure 3).



Figure 3: Tube inside the valve guard.

3. Pass the safety wire through both of the hydraulic hose cutouts on the gripper assembly (see Figure 4, Figure 5 and Figure 6).



Figure 4: Pass the safety wire through the hole with the hydraulic hose.



Figure 5: Safety wire routing.

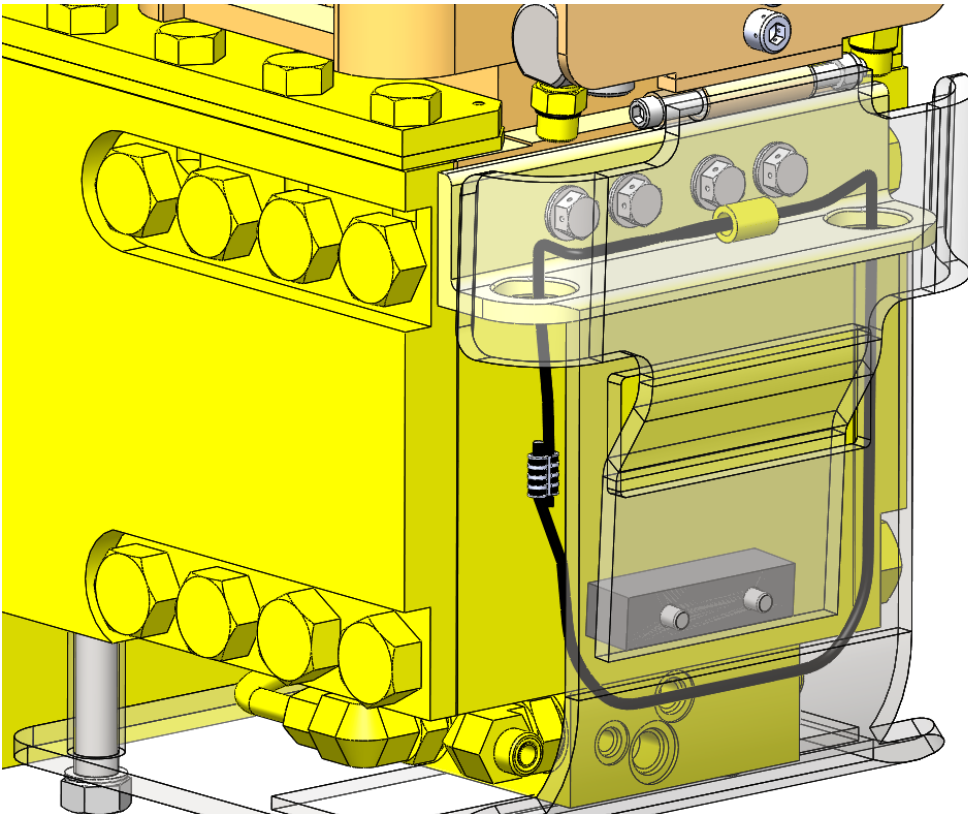

Figure 6: Safety wire routing.

4. Insert the safety wire ends into the aluminum ferrule. Ensure the wire extends no more than $\frac{1}{4}$ " beyond the ferrule, and then use the crimping tool to crimp the cable four times.



Note: Ensure the safety wire does not protrude and create a snag point.



Figure 7: Safety wire crimped in the ferrule.

5. Ensure the looped safety wire extends below the deflector and does not interfere with the movement of the deflector plate (refer to Figure 7).